



SWEDEGAS
SVVLEDGAS

SWEDEGAS LNG INVESTMENT IN THE PORT OF GOTHENBURG

Nautiska föreningen

Lindholmen 27th November, 2018

Lars Persson, Technical Manager LNG

SWEDEGAS

LNG

MARKET DEVELOPMENT

GO4LNG

P2J

Swedegas is investing in gas infrastructure

- Owns and operates (TSO) the Swedish gas grid
- Transports gas to distributors and end-users. The gas is used by industrial enterprises, combined heat and power plants, the transport sector and households.
- Develops new opportunities for the use of renewable gas and LNG for sustainability, competitiveness and security of supply



Founded	1976
Net sales ^(*)	MEUR 42 (2017)
Employees	40
Owner	EDIF II – First State

(*) EUR = 9,838 SEK

Swedegas vision

Swedegas is a leading company in the energy industry that develops and invests for sustainability and competitiveness

- 2030: 30 per cent of the energy in the Swedegas system will be renewable
- 2050: 100 per cent will be renewable
- 2018: (DSO + TSO) 22 per cent renewable



The Swedish gas market is developing

- 1 BCM market
- New gas-grid customers
- LNG for industry
- LNG as a bunker fuel for marine use
- LBG as a bunker fuel for marine use
- CNG/LNG/Biogas for road transport

- Share of renewable gas is growing in the grid



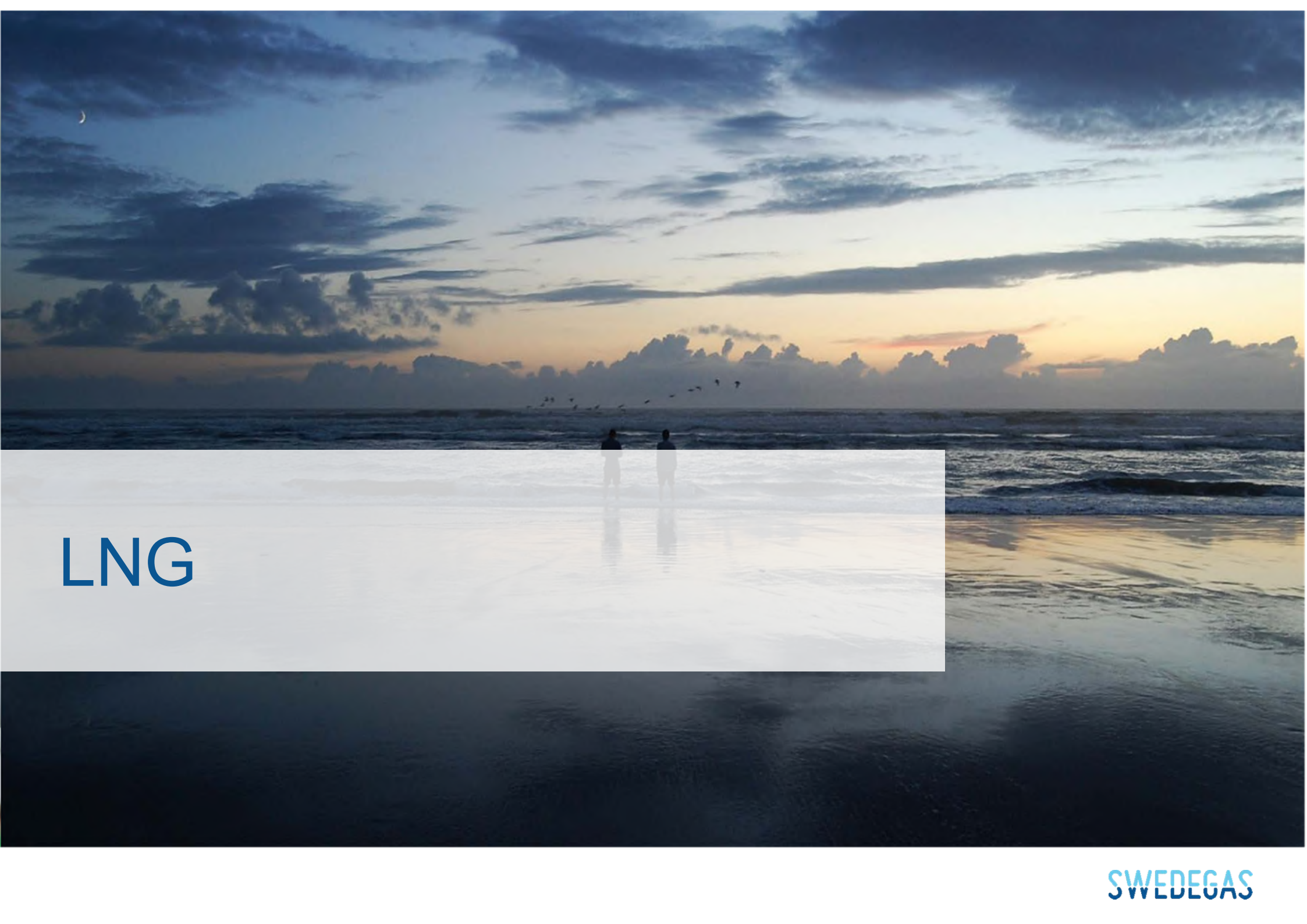

LNG

WHAT IS LNG?

LNG – Liquefied Natural Gas



Methane
CH₄



A clear, colorless, non-toxic liquid that forms when natural gas is cooled to -163°C (-260°F). This shrinks the volume of the gas 600 times,

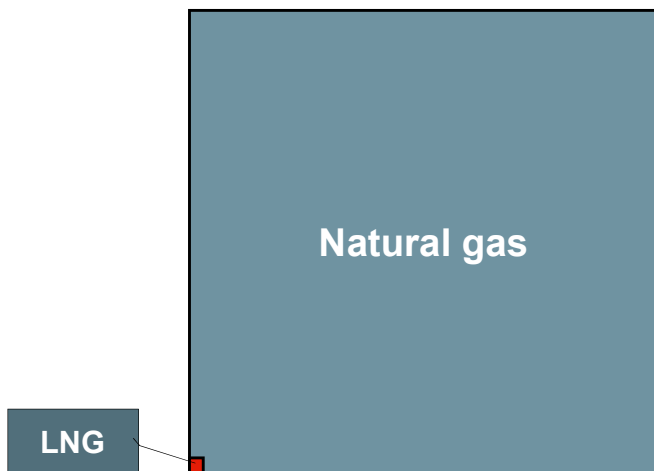
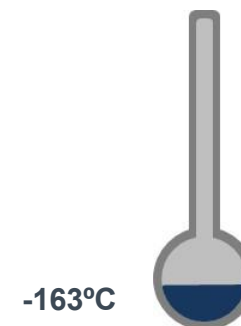

1 m³ LNG = 600 Nm³ naturgas

1 m ³ naturgas	= 11 kWh
1 m ³ LNG	= 6 600 kWh
1 m ³ Olja	= 9 800 kWh



WHY LNG

LNG is a Safe, Environmentally – Friendly Fuel

- Natural gas (LNG) is the cleanest burning fossil based fuel with 50% lower emissions than coal.
- The beauty of LNG's simplicity is that it burns almost completely, leaving only a small amount of carbon dioxide and water behind ($\text{CH}_4 + 2\text{O}_2 = \text{CO}_2 + 2\text{H}_2\text{O}$)
- LNG offers several benefits to both human health and the environment. Switching to LNG means complete removal of SOx and particles, and reduction of NOx emissions of up to 85%.
- In addition, LNG also reduces CO2 emissions by at least 20% less than oil

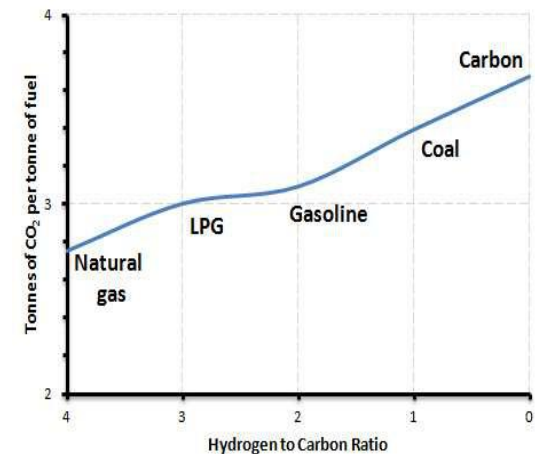

CO2 EMISSIONS VS. FUELS

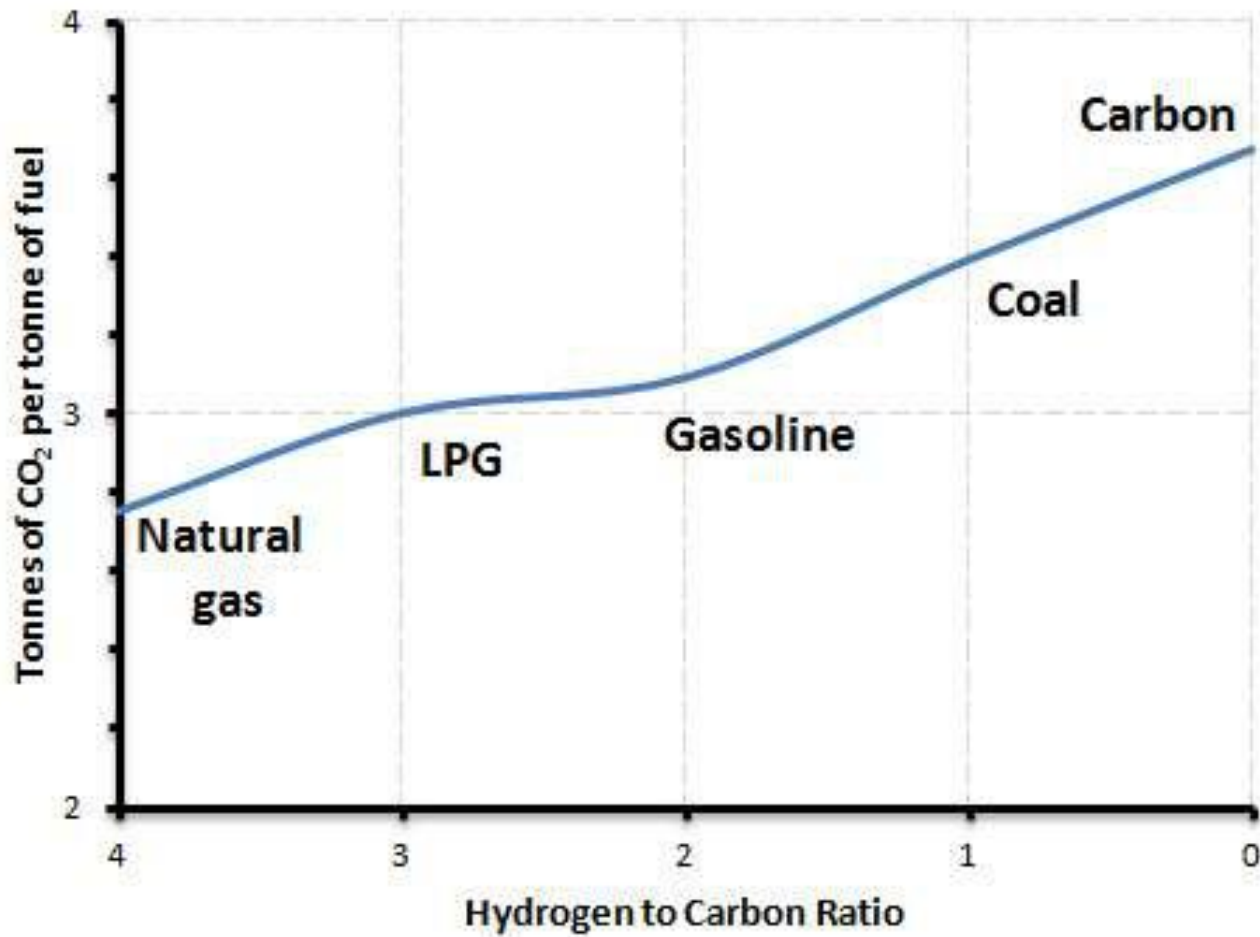



GO4LNG

FROM BUNKERING INFRASTRUCTURE TO A SMALL-SCALE LNG TERMINAL

LNG terminal in Gothenburg



 Co-financed by the European Union
Connecting Europe Facility

Gothenburg LNG Terminal as a hub in the Nordic region with an ideal location for reaching the whole of the Baltic region, Scandinavia, the North Sea and the Atlantic

The location: Port of Gothenburg



- Gothenburg is the **largest port in the Nordic region** and also Scandinavia main bunker hub with 1,5 Mton oil bunkered annually
- **11 000 vessel calls/yr** - energy, container, cars, ro-ro and passenger cruises
- Extensive liner services to key import and export markets throughout the world and a large number of point-to-point connections within the SECA zone
- **LNG is part of both the City of Gothenburg's and Port of Gothenburg's environmental program:** Incentives in the port dues, 20 percent discount
- **111** LNG calls 2017,
- **135** expected for full year 2018

Project background

The project targets the LNG bunkering market in the Port, the LNG supply to isolated customers in the Swedish hinterland and the pipeline gas market

- **100% Swedegas owned project**
- **Swedegas now supported by Fluxys & Enagas** to develop and realize the project
- **Permitting and EPC front work ongoing**
- **Negotiations regarding harbor agreement assured**
- Project is **supported by the European Commission**, has PCI status
- **Concession application** handed in to EI
- **Scalable concept**

Permit to store up
33.000m³ LNG!



Go4LNG as a multiple uses terminal developing a scalable, flexible and sustainable concept...serving as an LNG distribution platform

- Conceptual design finished
- Storage concept **depending on market needs** : **full containment tank** (~ 25.000m³) and/or **bullets** (~ 8.000m³)
- Scalable solution
- All permits obtained. Grid connection permit handed in.
- Negotiations regarding **harbor agreement assured**
- Project is **supported by the European Commission**, has PCI status in the 3rd list
- **Regulated, open access terminal**
- Negotiations ongoing with key **potential customers**
- **FID envisaged during 2019 and operational 2020-2021**

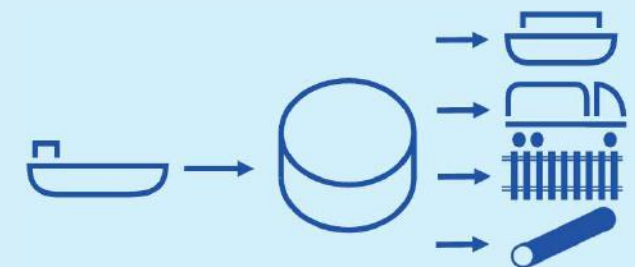
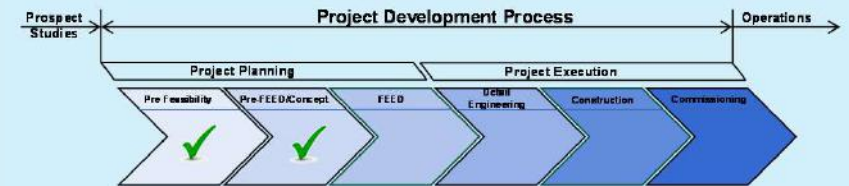

Targeted segments:



Go4LNG will supply LNG as a **bunker fuel** in the Gothenburg-Skagen area, to **isolated customers** in the Swedish hinterland and the **pipeline** gas grid market

LNG Gothenburg

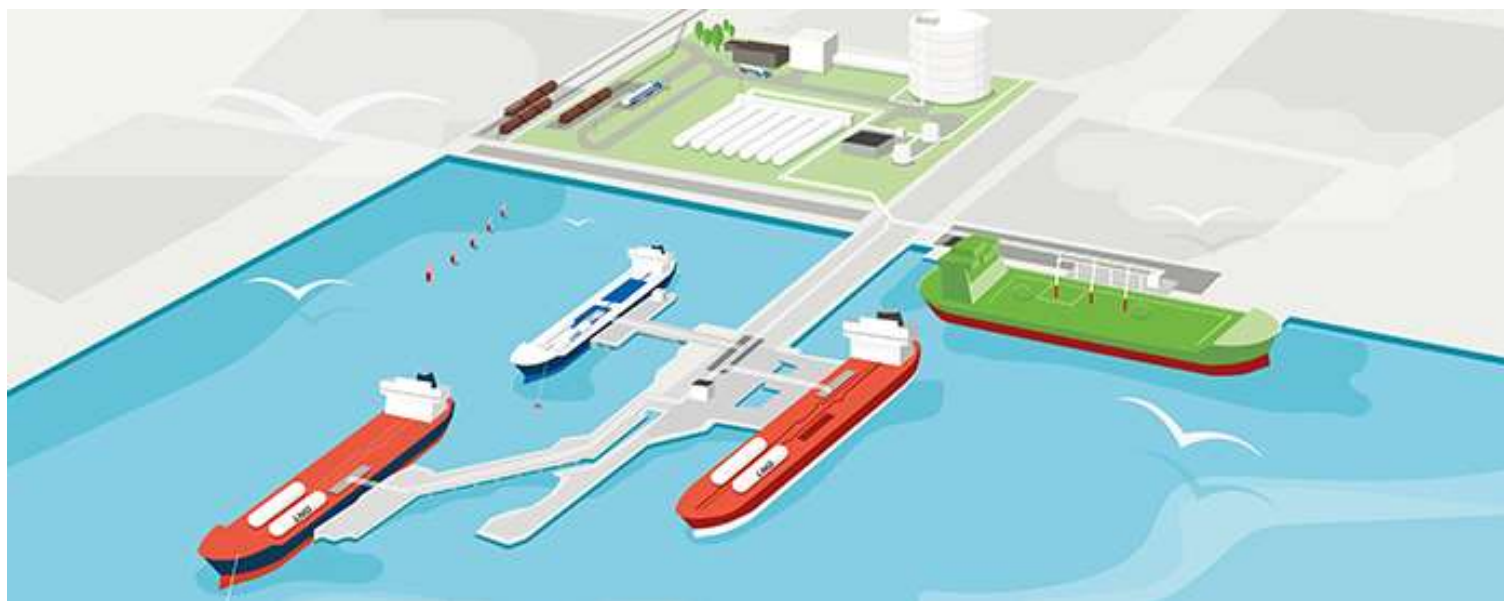

Svenska

<https://youtu.be/DTQ0vCTE0I8>

English

<https://www.youtube.com/watch?v=hBYsPDcFYtA>

Scalable concept - LNG terminal

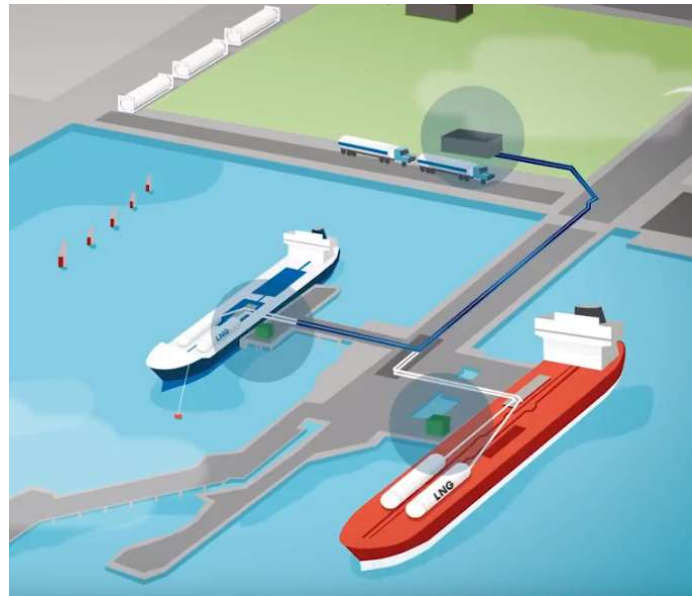
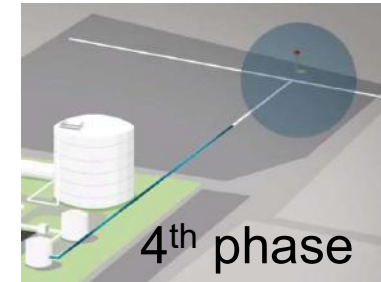

1st phase

2nd phase

3rd phase

Unloading station for
truck and containers

Bullet tanks and ship
unloading

Full scale LNG import
terminal

No storage capacity

1000 m³ – 8000 m³
storage capacity

33 000m³ storage capacity



1ST PHASE FLEXIBLE BUNKERING INFRASTRUCTURE IN GOTHENBURG

Pipe to jetty as frontrunner of Gothenburg terminal...

- Ship owners/fuel buyers have **requested** to bunker LNG simultaneously while loading / unloading products
- Trucks cannot enter the jetty. A **cryogenic pipeline** will connect shore to ship.
- Follows the **open access principle**
- **1st phase:** LNG from truck/containers to ship through pipe
- **2nd phase:** Pipe connected to the Go4LNG terminal
- **FID** taken June 2017
- The 1st phase is operational since July **2018**



Co-financed by the European Union
Connecting Europe Facility

...the market is already there...

- **15 ordered LNG fuelled tankers** could potentially visit Port of Gothenburg
 - 5 tankers 2016-2017 (currently operational)
 - Other 10 before 2019
- **Terntank** has taken **4 LNG fuelled tankers** into service
- **Gothia Tanker Alliance** has ordered **10 new LNG fuelled tankers** and has **1 retrofit** in operation

Volume cases based on discussion with end users, LNG suppliers and Swedegas internal assessment



Source: Gothia Tanker Alliance newly ordered LNG driven vessels

Bunkering volume on the bunker pipe estimated between 30.000 and 70.000 m³ LNG /y



Source: Terntank

LNG fuelled ships tank :
~ 300 - 600 m³

...with a considerable market potential.

SECA regulation

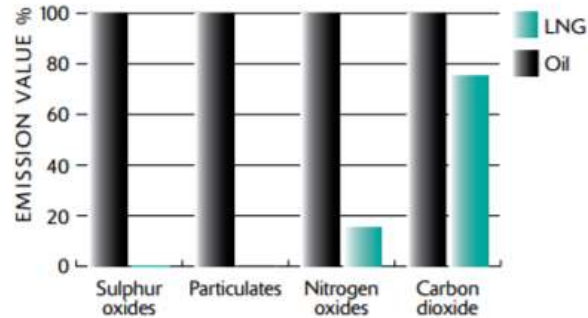

If LNG/natural gas is used instead of oil, emissions of sulphur and particulates are reduced to almost zero. Emissions of nitrogen oxide are reduced by almost 90 per cent and carbon dioxide by approximately 25 per cent.

High density and ships routes passing by Gothenburg

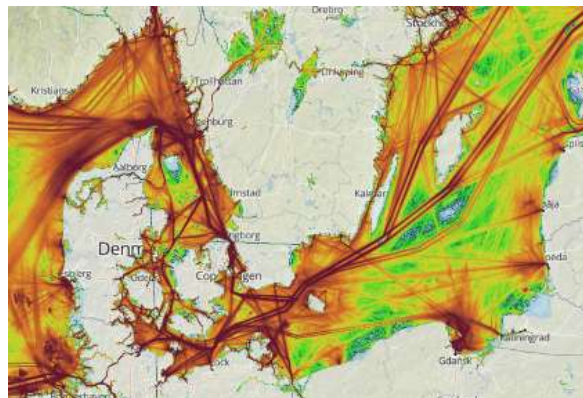

Source: marinetraffic

LNG-fuelled vessels

Yearly development of fleet

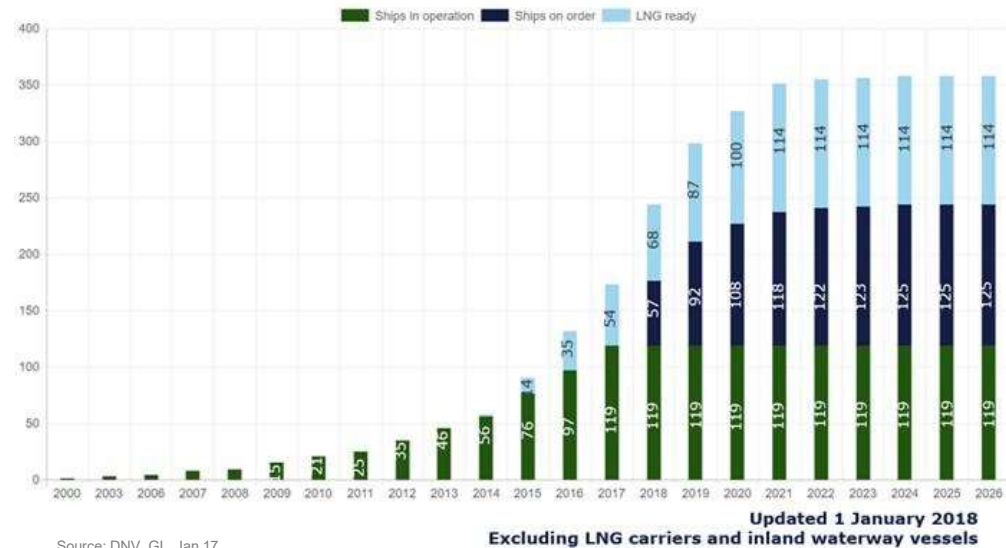

Source: DNV, GL Jan 17

Operating area of the 119 ships in operation

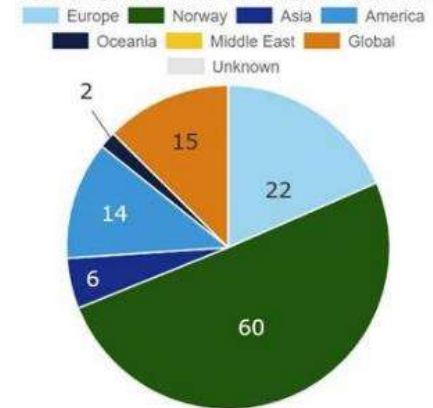

Operating area of the 125 ships on order

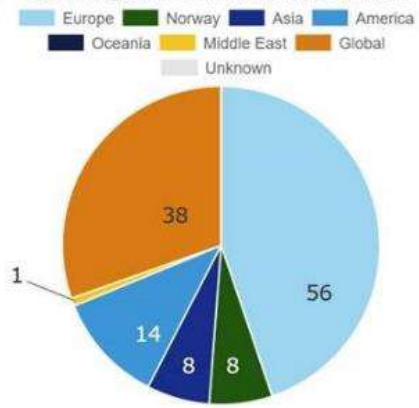

Source: DNV, GL Jan 18

Updated 1 January 2018
Excluding LNG carriers and inland waterway vessels

...supported with an efficient logistic chain...

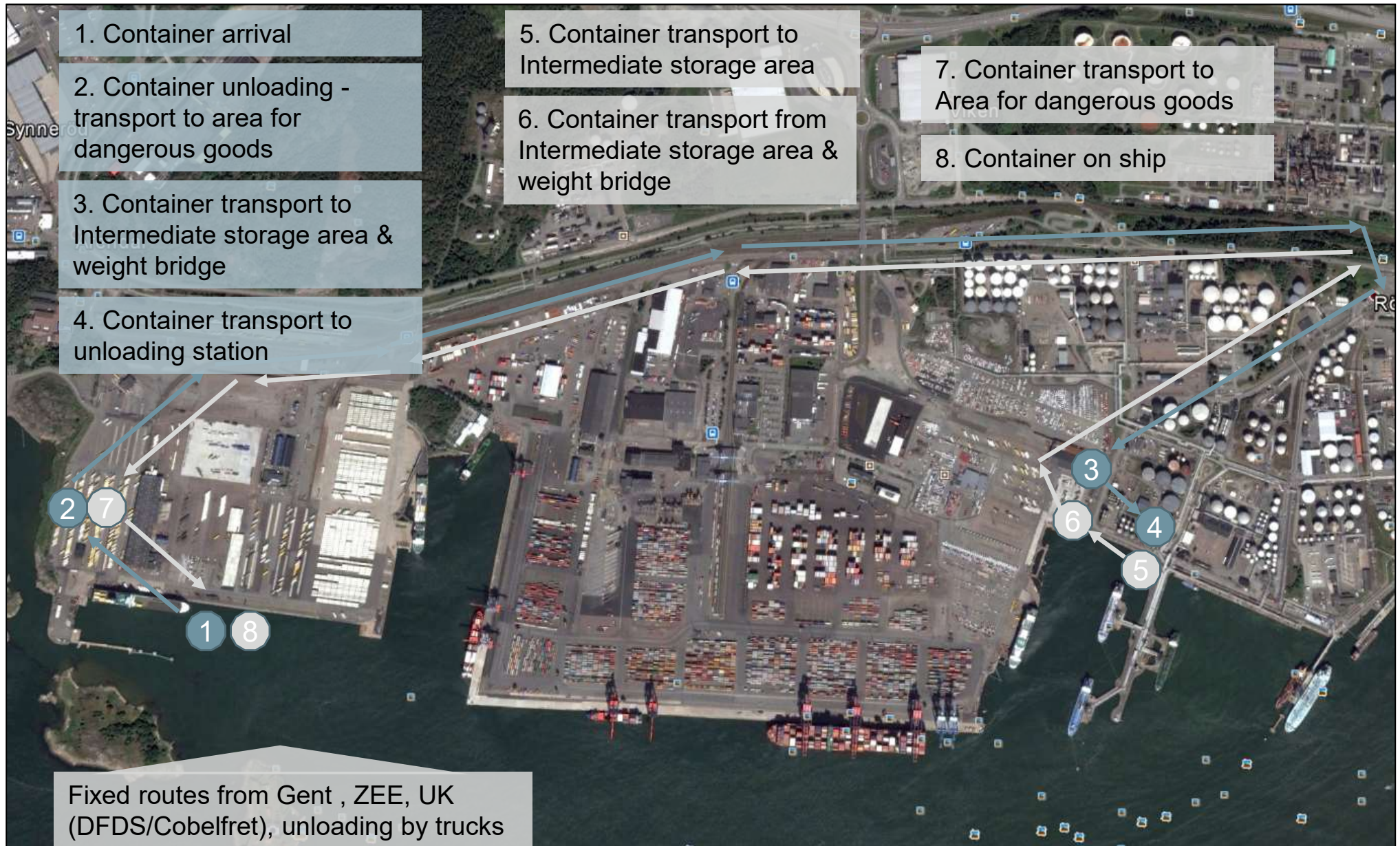

Unloading station - Skarvik



2 unloading station & 2 jetties connected

Technical details

- **Truck receiving / loading bay:** LNG ISO containers on a truck /LNG trucks
- **LNG ships tank :** ~ 300 - 600 m³
- **Pipe length:** ~ 500 m (including jetty 519+521),
- **Design:** to operate for ISO containers sequentially
- **LNG pumps:** ~ 50 - 75 m³/h external,
- External P.B.U. (Pressure Build-up Units)
- **Flow rate (design):** 100 m³/h
- **Pipe type:** Pipe in Pipe (VIP type), inner pipe 4" (DN 100, PN16).
- **Connection to the jetty:** Hoses equipped with quick connection
- No vapor return line
- Other equipment: N₂ package, LNG coriolis measurement
- **Ships size:** 100-150 m length

Base assumptions

- 7 Containers per loading – total volume ~ 300m³ LNG
- Two unloading stations with one pump per station for LNG bunkering
- One container in operation while connecting the 2nd & automatic switch over
- 10-12 hours bunkering time



Technical and operational concept



Container/
Trailer*



Ship

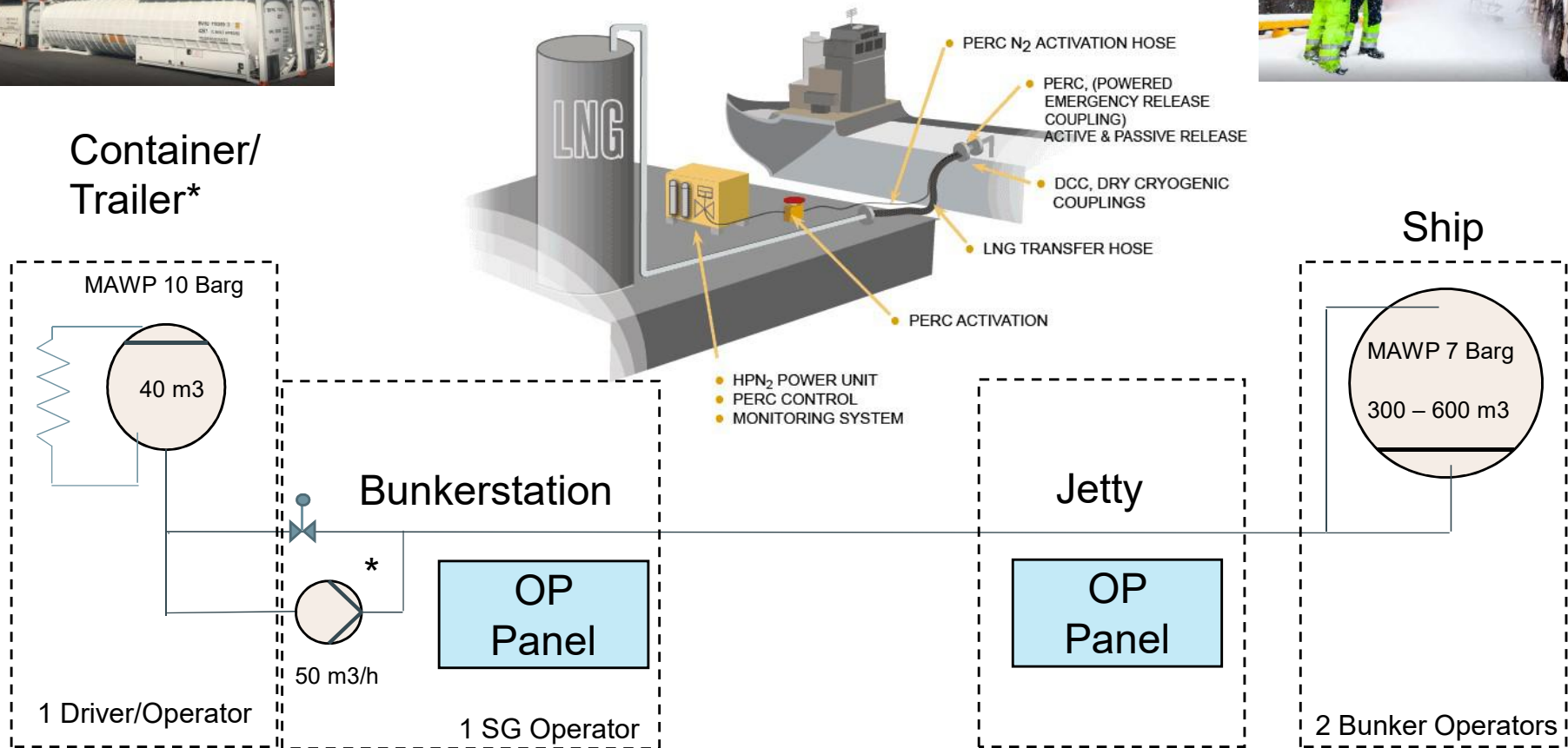

* Pump included in trailer

Process diagram

Cold flare

PBU

Pump

Flow meter

ESD & SIGTTO connection

VAP

Knock out drum

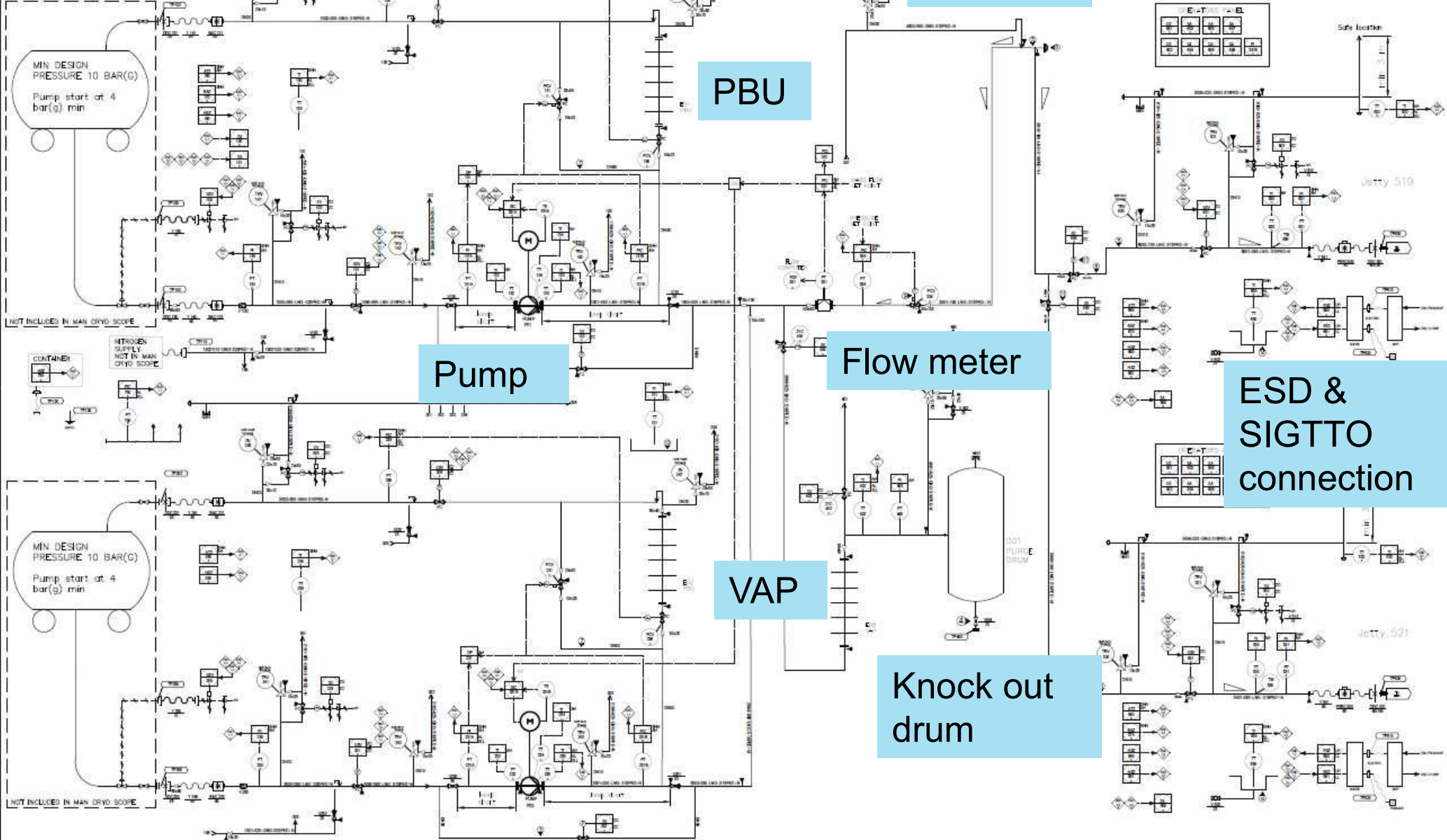

NOTES:
 1. DOUBLE LINES FOR LIE
 2. TE, T, T₁, T₂, F, F₁, F₂, E, E₁, E₂, L, L₁, L₂, P, P₁, P₂, S, S₁, S₂, I, I₁, I₂, M, M₁, M₂, C, C₁, C₂, D, D₁, D₂, V, V₁, V₂, B, B₁, B₂, R, R₁, R₂, A, A₁, A₂, Y, Y₁, Y₂, Z, Z₁, Z₂, J, J₁, J₂, K, K₁, K₂, L, L₁, L₂, M, M₁, M₂, N, N₁, N₂, O, O₁, O₂, P, P₁, P₂, Q, Q₁, Q₂, R, R₁, R₂, S, S₁, S₂, T, T₁, T₂, U, U₁, U₂, V, V₁, V₂, W, W₁, W₂, X, X₁, X₂, Y, Y₁, Y₂, Z, Z₁, Z₂, AA, AA₁, AA₂, AB, AB₁, AB₂, AC, AC₁, AC₂, AD, AD₁, AD₂, AE, AE₁, AE₂, AF, AF₁, AF₂, AG, AG₁, AG₂, AH, AH₁, AH₂, AI, AI₁, AI₂, AJ, AJ₁, AJ₂, AK, AK₁, AK₂, AL, AL₁, AL₂, AM, AM₁, AM₂, AN, AN₁, AN₂, AO, AO₁, AO₂, AP, AP₁, AP₂, AQ, AQ₁, AQ₂, AR, AR₁, AR₂, AS, AS₁, AS₂, AT, AT₁, AT₂, AU, AU₁, AU₂, AV, AV₁, AV₂, AW, AW₁, AW₂, AX, AX₁, AX₂, AY, AY₁, AY₂, AZ, AZ₁, AZ₂, BA, BA₁, BA₂, BB, BB₁, BB₂, BC, BC₁, BC₂, BD, BD₁, BD₂, BE, BE₁, BE₂, BF, BF₁, BF₂, BG, BG₁, BG₂, BH, BH₁, BH₂, BI, BI₁, BI₂, BJ, BJ₁, BJ₂, BK, BK₁, BK₂, BL, BL₁, BL₂, BM, BM₁, BM₂, BN, BN₁, BN₂, BO, BO₁, BO₂, BP, BP₁, BP₂, BQ, BQ₁, BQ₂, BR, BR₁, BR₂, BS, BS₁, BS₂, BT, BT₁, BT₂, BU, BU₁, BU₂, BV, BV₁, BV₂, BW, BW₁, BW₂, BX, BX₁, BX₂, BY, BY₁, BY₂, BZ, BZ₁, BZ₂, CA, CA₁, CA₂, CB, CB₁, CB₂, CC, CC₁, CC₂, CD, CD₁, CD₂, CE, CE₁, CE₂, CF, CF₁, CF₂, CG, CG₁, CG₂, CH, CH₁, CH₂, CI, CI₁, CI₂, CJ, CJ₁, CJ₂, CK, CK₁, CK₂, CL, CL₁, CL₂, CM, CM₁, CM₂, CN, CN₁, CN₂, CO, CO₁, CO₂, CP, CP₁, CP₂, CQ, CQ₁, CQ₂, CR, CR₁, CR₂, CS, CS₁, CS₂, CT, CT₁, CT₂, CU, CU₁, CU₂, CV, CV₁, CV₂, CW, CW₁, CW₂, CX, CX₁, CX₂, CY, CY₁, CY₂, CZ, CZ₁, CZ₂, DA, DA₁, DA₂, DB, DB₁, DB₂, DC, DC₁, DC₂, DD, DD₁, DD₂, DE, DE₁, DE₂, DF, DF₁, DF₂, DG, DG₁, DG₂, DH, DH₁, DH₂, DI, DI₁, DI₂, DJ, DJ₁, DJ₂, DK, DK₁, DK₂, DL, DL₁, DL₂, DM, DM₁, DM₂, DN, DN₁, DN₂, DO, DO₁, DO₂, DP, DP₁, DP₂, DQ, DQ₁, DQ₂, DR, DR₁, DR₂, DS, DS₁, DS₂, DT, DT₁, DT₂, DU, DU₁, DU₂, DV, DV₁, DV₂, DW, DW₁, DW₂, DX, DX₁, DX₂, DY, DY₁, DY₂, DZ, DZ₁, DZ₂, EA, EA₁, EA₂, EB, EB₁, EB₂, EC, EC₁, EC₂, ED, ED₁, ED₂, EE, EE₁, EE₂, EF, EF₁, EF₂, EG, EG₁, EG₂, EH, EH₁, EH₂, EI, EI₁, EI₂, EJ, EJ₁, EJ₂, EK, EK₁, EK₂, EL, EL₁, EL₂, EM, EM₁, EM₂, EN, EN₁, EN₂, EO, EO₁, EO₂, EP, EP₁, EP₂, EQ, EQ₁, EQ₂, ER, ER₁, ER₂, ES, ES₁, ES₂, ET, ET₁, ET₂, EU, EU₁, EU₂, EV, EV₁, EV₂, EW, EW₁, EW₂, EX, EX₁, EX₂, EY, EY₁, EY₂, EZ, EZ₁, EZ₂, FA, FA₁, FA₂, FB, FB₁, FB₂, FC, FC₁, FC₂, FD, FD₁, FD₂, FE, FE₁, FE₂, FF, FF₁, FF₂, FG, FG₁, FG₂, FH, FH₁, FH₂, FI, FI₁, FI₂, FJ, FJ₁, FJ₂, FK, FK₁, FK₂, FL, FL₁, FL₂, FM, FM₁, FM₂, FN, FN₁, FN₂, FO, FO₁, FO₂, FP, FP₁, FP₂, FQ, FQ₁, FQ₂, FR, FR₁, FR₂, FS, FS₁, FS₂, FT, FT₁, FT₂, FU, FU₁, FU₂, FV, FV₁, FV₂, FW, FW₁, FW₂, FX, FX₁, FX₂, FY, FY₁, FY₂, FZ, FZ₁, FZ₂, GA, GA₁, GA₂, GB, GB₁, GB₂, GC, GC₁, GC₂, GD, GD₁, GD₂, GE, GE₁, GE₂, GF, GF₁, GF₂, GG, GG₁, GG₂, GH, GH₁, GH₂, GI, GI₁, GI₂, GJ, GJ₁, GJ₂, GK, GK₁, GK₂, GL, GL₁, GL₂, GM, GM₁, GM₂, GN, GN₁, GN₂, GO, GO₁, GO₂, GP, GP₁, GP₂, GQ, GQ₁, GQ₂, GR, GR₁, GR₂, GS, GS₁, GS₂, GT, GT₁, GT₂, GU, GU₁, GU₂, GV, GV₁, GV₂, GW, GW₁, GW₂, GX, GX₁, GX₂, GY, GY₁, GY₂, GZ, GZ₁, GZ₂, HA, HA₁, HA₂, HB, HB₁, HB₂, HC, HC₁, HC₂, HD, HD₁, HD₂, HE, HE₁, HE₂, HF, HF₁, HF₂, HG, HG₁, HG₂, HH, HH₁, HH₂, HI, HI₁, HI₂, HJ, HJ₁, HJ₂, HK, HK₁, HK₂, HL, HL₁, HL₂, HM, HM₁, HM₂, HN, HN₁, HN₂, HO, HO₁, HO₂, HP, HP₁, HP₂, HQ, HQ₁, HQ₂, HR, HR₁, HR₂, HS, HS₁, HS₂, HT, HT₁, HT₂, HU, HU₁, HU₂, HV, HV₁, HV₂, HW, HW₁, HW₂, HX, HX₁, HX₂, HY, HY₁, HY₂, HZ, HZ₁, HZ₂, IA, IA₁, IA₂, IB, IB₁, IB₂, IC, IC₁, IC₂, ID, ID₁, ID₂, IE, IE₁, IE₂, IF, IF₁, IF₂, IG, IG₁, IG₂, IH, IH₁, IH₂, II, II₁, II₂, IJ, IJ₁, IJ₂, IK, IK₁, IK₂, IL, IL₁, IL₂, IM, IM₁, IM₂, IN, IN₁, IN₂, IO, IO₁, IO₂, IP, IP₁, IP₂, IQ, IQ₁, IQ₂, IR, IR₁, IR₂, IS, IS₁, IS₂, IT, IT₁, IT₂, IU, IU₁, IU₂, IV, IV₁, IV₂, IW, IW₁, IW₂, IX, IX₁, IX₂, IY, IY₁, IY₂, IZ, IZ₁, IZ₂, JA, JA₁, JA₂, JB, JB₁, JB₂, JC, JC₁, JC₂, JD, JD₁, JD₂, JE, JE₁, JE₂, JF, JF₁, JF₂, JG, JG₁, JG₂, JH, JH₁, JH₂, JI, JI₁, JI₂, JJ, JJ₁, JJ₂, JK, JK₁, JK₂, JL, JL₁, JL₂, JM, JM₁, JM₂, JN, JN₁, JN₂, JO, JO₁, JO₂, JP, JP₁, JP₂, JQ, JQ₁, JQ₂, JR, JR₁, JR₂, JS, JS₁, JS₂, JT, JT₁, JT₂, JU, JU₁, JU₂, JV, JV₁, JV₂, JW, JW₁, JW₂, JX, JX₁, JX₂, JY, JY₁, JY₂, JZ, JZ₁, JZ₂, KA, KA₁, KA₂, KB, KB₁, KB₂, KC, KC₁, KC₂, KD, KD₁, KD₂, KE, KE₁, KE₂, KF, KF₁, KF₂, KG, KG₁, KG₂, KH, KH₁, KH₂, KI, KI₁, KI₂, KJ, KJ₁, KJ₂, KK, KK₁, KK₂, KL, KL₁, KL₂, KM, KM₁, KM₂, KN, KN₁, KN₂, KO, KO₁, KO₂, KP, KP₁, KP₂, KQ, KQ₁, KQ₂, KR, KR₁, KR₂, KS, KS₁, KS₂, KT, KT₁, KT₂, KU, KU₁, KU₂, KV, KV₁, KV₂, KW, KW₁, KW₂, KX, KX₁, KX₂, KY, KY₁, KY₂, KZ, KZ₁, KZ₂, LA, LA₁, LA₂, LB, LB₁, LB₂, LC, LC₁, LC₂, LD, LD₁, LD₂, LE, LE₁, LE₂, LF, LF₁, LF₂, LG, LG₁, LG₂, LH, LH₁, LH₂, LI, LI₁, LI₂, LJ, LJ₁, LJ₂, LK, LK₁, LK₂, LL, LL₁, LL₂, LM, LM₁, LM₂, LN, LN₁, LN₂, LO, LO₁, LO₂, LP, LP₁, LP₂, LQ, LQ₁, LQ₂, LR, LR₁, LR₂, LS, LS₁, LS₂, LT, LT₁, LT₂, LU, LU₁, LU₂, LV, LV₁, LV₂, LW, LW₁, LW₂, LX, LX₁, LX₂, LY, LY₁, LY₂, LZ, LZ₁, LZ₂, MA, MA₁, MA₂, MB, MB₁, MB₂, MC, MC₁, MC₂, MD, MD₁, MD₂, ME, ME₁, ME₂, MF, MF₁, MF₂, MG, MG₁, MG₂, MH, MH₁, MH₂, MI, MI₁, MI₂, MJ, MJ₁, MJ₂, MK, MK₁, MK₂, ML, ML₁, ML₂, MM, MM₁, MM₂, MN, MN₁, MN₂, MO, MO₁, MO₂, MP, MP₁, MP₂, MQ, MQ₁, MQ₂, MR, MR₁, MR₂, MS, MS₁, MS₂, MT, MT₁, MT₂, MU, MU₁, MU₂, MV, MV₁, MV₂, MW, MW₁, MW₂, MX, MX₁, MX₂, MY, MY₁, MY₂, MZ, MZ₁, MZ₂, NA, NA₁, NA₂, NB, NB₁, NB₂, NC, NC₁, NC₂, ND, ND₁, ND₂, NE, NE₁, NE₂, NF, NF₁, NF₂, NG, NG₁, NG₂, NH, NH₁, NH₂, NI, NI₁, NI₂, NJ, NJ₁, NJ₂, NK, NK₁, NK₂, NL, NL₁, NL₂, NM, NM₁, NM₂, NN, NN₁, NN₂, NO, NO₁, NO₂, NP, NP₁, NP₂, NQ, NQ₁, NQ₂, NR, NR₁, NR₂, NS, NS₁, NS₂, NT, NT₁, NT₂, NU, NU₁, NU₂, NV, NV₁, NV₂, NW, NW₁, NW₂, NX, NX₁, NX₂, NY, NY₁, NY₂, NZ, NZ₁, NZ₂, OA, OA₁, OA₂, OB, OB₁, OB₂, OC, OC₁, OC₂, OD, OD₁, OD₂, OE, OE₁, OE₂, OF, OF₁, OF₂, OG, OG₁, OG₂, OH, OH₁, OH₂, OI, OI₁, OI₂, OJ, OJ₁, OJ₂, OK, OK₁, OK₂, OL, OL₁, OL₂, OM, OM₁, OM₂, ON, ON₁, ON₂, OO, OO₁, OO₂, OP, OP₁, OP₂, OQ, OQ₁, OQ₂, OR, OR₁, OR₂, OS, OS₁, OS₂, OT, OT₁, OT₂, OU, OU₁, OU₂, OV, OV₁, OV₂, OW, OW₁, OW₂, OX, OX₁, OX₂, OY, OY₁, OY₂, OZ, OZ₁, OZ₂, PA, PA₁, PA₂, PB, PB₁, PB₂, PC, PC₁, PC₂, PD, PD₁, PD₂, PE, PE₁, PE₂, PF, PF₁, PF₂, PG, PG₁, PG₂, PH, PH₁, PH₂, PI, PI₁, PI₂, PJ, PJ₁, PJ₂, PK, PK₁, PK₂, PL, PL₁, PL₂, PM, PM₁, PM₂, PN, PN₁, PN₂, PO, PO₁, PO₂, PP, PP₁, PP₂, PQ, PQ₁, PQ₂, PR, PR₁, PR₂, PS, PS₁, PS₂, PT, PT₁, PT₂, PU, PU₁, PU₂, PV, PV₁, PV₂, PW, PW₁, PW₂, PX, PX₁, PX₂, PY, PY₁, PY₂, PZ, PZ₁, PZ₂, QA, QA₁, QA₂, QB, QB₁, QB₂, QC, QC₁, QC₂, QD, QD₁, QD₂, QE, QE₁, QE₂, QF, QF₁, QF₂, QG, QG₁, QG₂, QH, QH₁, QH₂, QI, QI₁, QI₂, QJ, QJ₁, QJ₂, QK, QK₁, QK₂, QL, QL₁, QL₂, QM, QM₁, QM₂, QN, QN₁, QN₂, QO, QO₁, QO₂, QP, QP₁, QP₂, QQ, QQ₁, QQ₂, QR, QR₁, QR₂, QS, QS₁, QS₂, QT, QT₁, QT₂, QU, QU₁, QU₂, QV, QV₁, QV₂, QW, QW₁, QW₂, QX, QX₁, QX₂, QY, QY₁, QY₂, QZ, QZ₁, QZ₂, RA, RA₁, RA₂, RB, RB₁, RB₂, RC, RC₁, RC₂, RD, RD₁, RD₂, RE, RE₁, RE₂, RF, RF₁, RF₂, RG, RG₁, RG₂, RH, RH₁, RH₂, RI, RI₁, RI₂, RJ, RJ₁, RJ₂, RK, RK₁, RK₂, RL, RL₁, RL₂, RM, RM₁, RM₂, RN, RN₁, RN₂, RO, RO₁, RO₂, RP, RP₁, RP₂, RQ, RQ₁, RQ₂, RR, RR₁, RR₂, RS, RS₁, RS₂, RT, RT₁, RT₂, RU, RU₁, RU₂, RV, RV₁, RV₂, RW, RW₁, RW₂, RX, RX₁, RX₂, RY, RY₁, RY₂, RZ, RZ₁, RZ₂, SA, SA₁, SA₂, SB, SB₁, SB₂, SC, SC₁, SC₂, SD, SD₁, SD₂, SE, SE₁, SE₂, SF, SF₁, SF₂, SG, SG₁, SG₂, SH, SH₁, SH₂, SI, SI₁, SI₂, SJ, SJ₁, SJ₂, SK, SK₁, SK₂, SL, SL₁, SL₂, SM, SM₁, SM₂, SN, SN₁, SN₂, SO, SO₁, SO₂, SP, SP₁, SP₂, SQ, SQ₁, SQ₂, SR, SR₁, SR₂, SS, SS₁, SS₂, ST, ST₁, ST₂, SU, SU₁, SU₂, SV, SV₁, SV₂, SW, SW₁, SW₂, SX, SX₁, SX₂, SY, SY₁, SY₂, SZ, SZ₁, SZ₂, TA, TA₁, TA₂, TB, TB₁, TB₂, TC, TC₁, TC₂, TD, TD₁, TD₂, TE, TE₁, TE₂, TF, TF₁, TF₂, TG, TG₁, TG₂, TH, TH₁, TH₂, TI, TI₁, TI₂, TJ, TJ₁, TJ₂, TK, TK₁, TK₂, TL, TL₁, TL₂, TM, TM₁, TM₂, TN, TN₁, TN₂, TO, TO₁, TO₂, TP, TP₁, TP₂, TQ, TQ₁, TQ₂, TR, TR₁, TR₂, TS, TS₁, TS₂, TU, TU₁, TU₂, TV, TV₁, TV₂, TW, TW₁, TW₂, TX, TX₁, TX₂, TY, TY₁, TY₂, TZ, TZ₁, TZ₂, UA, UA₁, UA₂, UB, UB₁, UB₂, UC, UC₁, UC₂, UD, UD₁, UD₂, UE, UE₁, UE₂, UF, UF₁, UF₂, UG, UG₁, UG₂, UH, UH₁, UH₂, UI, UI₁, UI₂, UJ, UJ₁, UJ₂, UK, UK₁, UK₂, UL, UL₁, UL₂, UM, UM₁, UM₂, UN, UN₁, UN₂, UO, UO₁, UO₂, UP, UP₁, UP₂, UQ, UQ₁, UQ₂, UR, UR₁, UR₂, US, US₁, US₂, UT, UT₁, UT₂, UU, UU₁, UU₂, UV, UV₁, UV₂, UW, UW₁, UW₂, UX, UX₁, UX₂, UY, UY₁, UY₂, UZ, UZ₁, UZ₂, VA, VA₁, VA₂, VB, VB₁, VB₂, VC, VC₁, VC₂, VD, VD₁, VD₂, VE, VE₁, VE₂, VF, VF₁, VF₂, VG, VG₁, VG₂, VH, VH₁, VH₂, VI, VI₁, VI₂, VJ, VJ₁, VJ₂, VK, VK₁, VK₂, VL, VL₁, VL₂, VM, VM₁, VM₂, VN, VN₁, VN₂, VO, VO₁, VO₂, VP, VP₁, VP₂, VQ, VQ₁, VQ₂, VR, VR₁, VR₂, VS, VS₁, VS₂, VT, VT₁, VT₂, VU, VU₁, VU₂, VV, VV₁, VV₂, VW, VW₁, VW₂, VX, VX₁, VX₂, VY, VY₁, VY₂, VZ, VZ₁, VZ₂, WA, WA₁, WA₂, WB, WB₁, WB₂, WC, WC₁, WC₂, WD, WD₁, WD₂, WE, WE₁, WE₂, WF, WF₁, WF₂, WG, WG₁, WG₂, WH, WH₁, WH₂, WI, WI₁, WI₂, WJ, WJ₁, WJ₂, WK, WK₁, WK₂, WL, WL₁, WL₂, WM, WM₁, WM₂, WN, WN₁, WN₂, WO, WO₁, WO₂, WP, WP₁, WP₂, WQ, WQ₁, WQ₂, WR, WR₁, WR₂, WS, WS₁, WS₂, WT, WT₁, WT₂, WU, WU₁, WU₂, WV, WV₁, WV₂, WX, WX₁, WX₂, WY, WY₁, WY₂, WZ, WZ₁, WZ₂, XA, XA₁, XA₂, XB, XB₁, XB₂, XC, XC₁, XC₂, XD, XD₁, XD₂, XE, XE₁, XE₂, XF, XF₁, XF₂, XG, XG₁, XG₂, XH, XH₁, XH₂, XI, XI₁, XI₂, XJ, XJ₁, XJ₂, XK, XK₁, XK₂, XL, XL₁, XL₂, XM, XM₁,

Trailer/ Container unloading Station



Cryogenic pump
840 l/min @ 20 m

Knock out drum 10m³
& Vaporizer

Trailer/ Container unloading Station



DCCoupling



Break away couplings



Vacuum insulated pipe

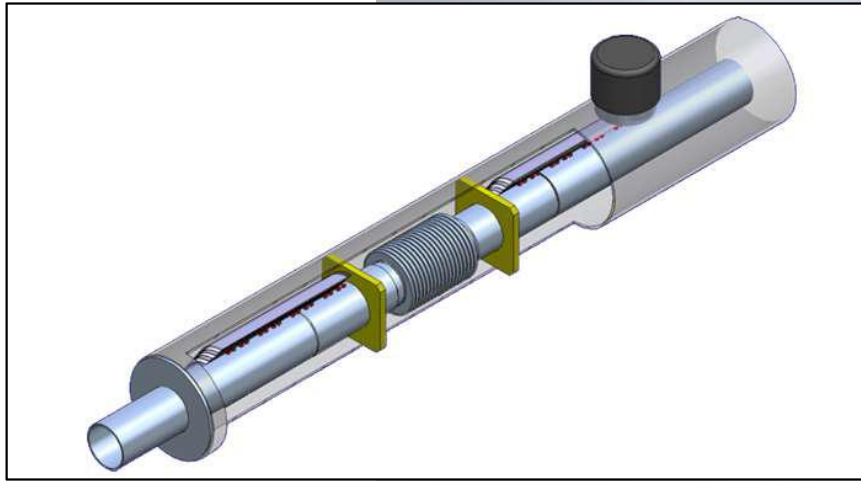

Heat Inleak
180 W/100m



~500 meters Vacuum insulated Pipe line

Bunker line out to jetty

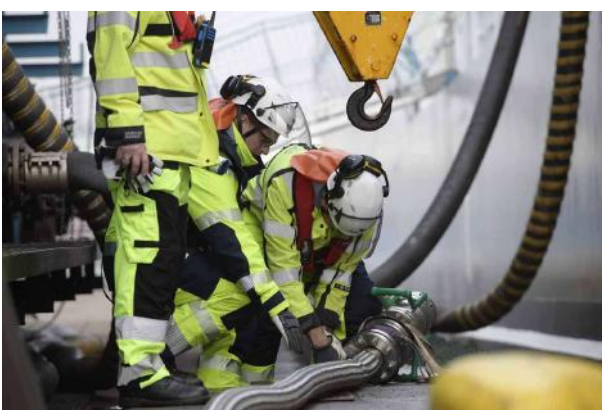

Loading hose – no loading arm

Bunkerstation at 519



DCCoupling and PERC

How does it works?

Pressure balance – cooling down

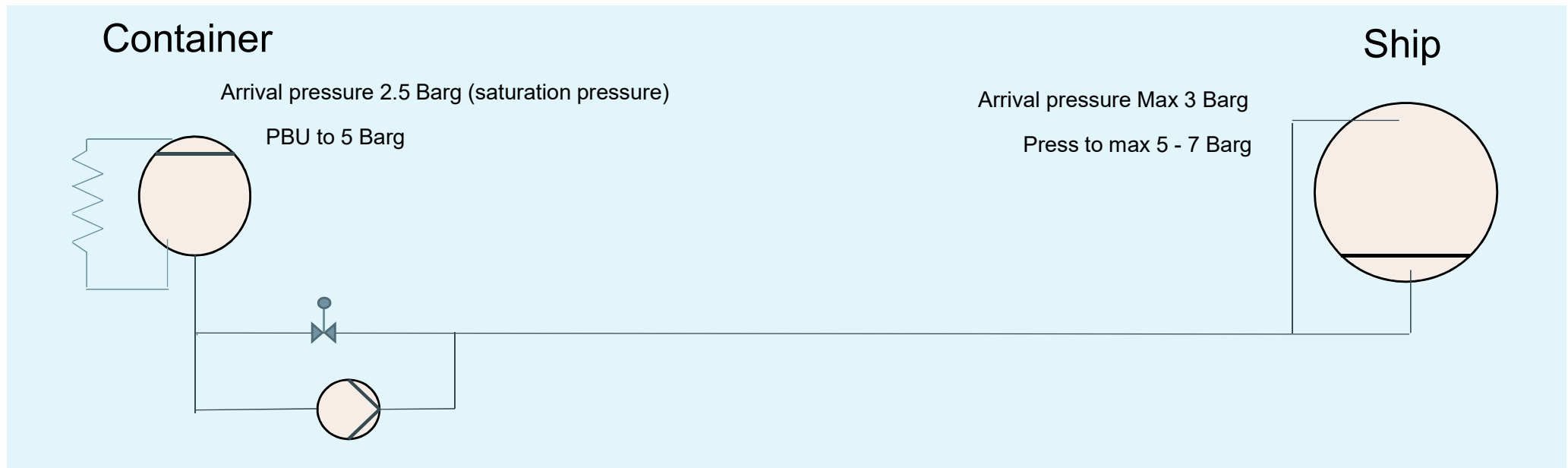

Start cooling – By pass
Start pumping – top spray

- Starting point warm pipeline
- 500kg LNG for cool down
- Automatic sequences & operations

Unloading LNG



PBU to Maintain Pump NPSH

Liq suction line and gas return

Emptying principle

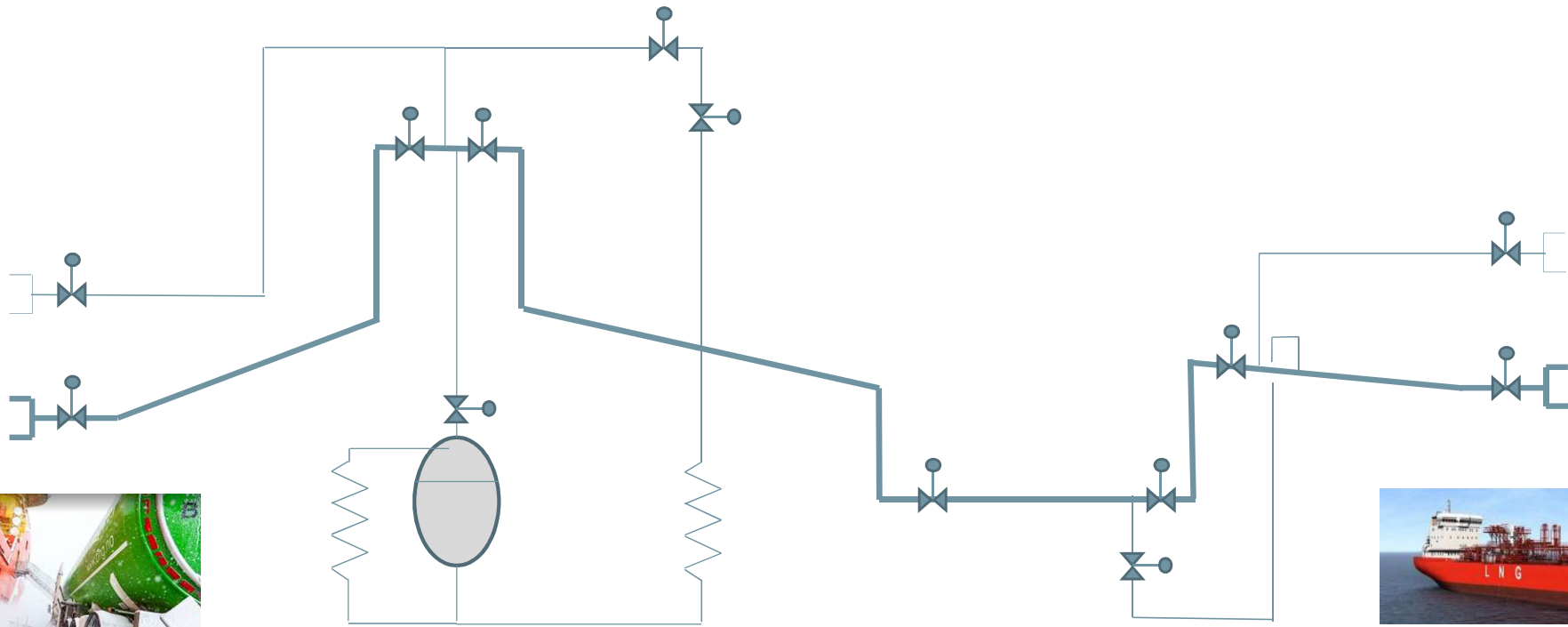

Pipe to Jetty



<https://vimeo.com/302353116/92587515a8>

Questions?





SWEDEGAS
SVEDEGAS

Thank you

Lars Persson

e-mail: lars.persson@swedegas.se